



MANUFACTURER OF ADVANCED SEWER AND PIPE INSPECTION CAMERA EQUIPMENT

insight | VISION

800-488-8177



FOLLOW, LIKE AND WATCH

OWNER'S MANUAL



If you need to contact Customer Service

For immediate assistance, contact Insight | Vision.

Phone: 800-488-8177

Fax: 262-268-9950

Email Technical Service: linda@insightvisioncameras.com

Email Sales & Support: bob@insightvisioncameras.com

Web Inquiry: www.insightvisioncameras.com

Please complete the following information for future reference:

Serial Number: _____

Date of Purchase: _____

Place of Purchase: _____

The serial number is on the back of the unit. Retain this User's Guide with your sales receipt as a permanent record of your purchase, in the event of theft, fire or warranty service.



TABLE OF CONTENTS

Warranty	3
Main System Controls	7
Remote Controls	9
Base Frame	10
Camera	12
F.A.Q.	14
Technical Data	17



WARRANTY

Insight | Vision warrants to the first purchaser that should any of its products prove to be defective in material or workmanship in normal use, within one (1) year from the date of delivery, Insight | Vision will, at its exclusive option, repair, replace or exchange the product or any of its parts.

THIS WARRANTY IS SUBJECT TO THE FOLLOWING LIMITATIONS:

1. This warranty does not apply to any product which has been subject to accident, negligence, alteration, abuse, misuse, overload, repair by anyone other than Insight | Vision or its authorized representatives, or not maintained in accordance with the manufacturer's suggested maintenance schedule.
2. This warranty applies only to components manufactured by Insight | Vision. The appropriate manufacturer's warranty, if any, shall apply to components not manufactured by the company.
3. This warranty does not apply to flex-link connectors, rod, LED light rings, cable, rollers, o-rings, and skids, or other parts, which are considered consumable. The replacement of these items is part of normal product maintenance.
4. This warranty shall not apply if the products are used or operated in any manner not consistent with their intended purpose.
5. This warranty is limited to repair or replacement of defective products and parts during the warranty period, and shall be the exclusive remedy. Insight | Vision shall in no event have any other obligation or liability of any nature arising from the breakdown, malfunction, defect or other failure of the product, including, without limitation, any liability for service, maintenance, repairs, personal injury, property damage, loss of profits, loss of use or other consequential damages.
6. Any action for any claimed breach of this warranty shall be brought within one (1) year from the date of delivery of the product.
7. The purchaser must return the defective product, part or component to the Insight | Vision, 600 N. Dekora Woods Blvd. factory in Saukville, WI 53080 at the purchaser's expense, properly and adequately packaged, with insurance and transportation pre-paid. Insight | Vision will either repair or replace the defective product, part or component, at its option, and will return it to the purchaser at the customer's expense. In no event shall Insight | Vision be liable for delay in repair or replacement and return under this warranty. Insight | Vision will endeavor to effect appropriate repairs in the shortest time practical, with respect to the customer having beneficial use of their equipment.
8. Insight | Vision neither assumes nor authorizes any person to assume any other liability or make any other warranty in connection with the products.
9. THIS WARRANTY IS EXPRESSLY GIVEN IN LIEU OF ALL OTHER WARRANTIES EXPRESSED OR IMPLIED. INSIGHT | VISION EXPRESSLY DISCLAIMS ANY OTHER WARRANTY, INCLUDING, WITHOUT LIMITATION, ANY WARRANTY OF MERCHANTABILITY OR FITNESS FOR A PARTICULAR PURPOSE.



SETTING UP D2 INSPECTION SYSTEM

SYSTEM MAINTENANCE REQUIREMENTS:

The following maintenance procedures are recommended for all Insight / VISION D2 Systems. Standard warranty policy dictates that components and accessories subject to wear and tear are not covered under the One (1) year warranty. Therefore we are strongly recommending that all systems be maintained according to the following procedures. Please be advised that Insight | VISION will not allow warranty coverage for these items if these procedures are not followed.

D2 COMMAND MODULE:

The D2 command module incorporates a USB port for recording options. These ports have no moving parts or recording heads so they do not require a cleaning device. However, if water, dirt or dust become present in these connectors due to extreme conditions in the field, owners/operators will be responsible for the cleaning of these connector/port areas using a Q-tip or other non-abrasive cleaning tool to remove the debris before inserting a USB memory stick.

Operating the Command Module:

Warning: All Insight | Vision's command modules are not water proof. Insight | Vision assumes no liability for any water damage, caused directly or indirectly, by improper usage of the system. Damage to the system components, the internal mother board, and injury to you may result if water is applied to the command module. **Water damage** will not be covered under warranty, **and may be cause for voiding of command module warranty.**



FAILURE TO FOLLOW THIS PROCEDURE INVALIDATES ANY WARRANTY CLAIM AGAINST OPTICAM FOR THE FUNCTIONALITY OF THE RECORDING DEVICE AND WARRANTY COVERAGE WILL NOT BE GRANTED.



O-Rings: O-rings are critical to insure the watertight integrity of the camera and connection areas. O-rings are subject to wear and tear and can also suffer failure due to age and other factors. They should be inspected regularly and replaced whenever needed.

When O-rings are working properly, a small amount of water and sometimes fine particles of grit will build up behind them. Any time the camera or sonde connection is taken apart and exposed, there exists the risk of grit wearing down or possibly even tearing the o-ring. It is also possible for water to then enter the connection area once exposed. All connections, once opened or exposed, **MUST** be thoroughly cleaned and dried before re-connecting. We recommend using an old toothbrush or other soft bristled brush to clean the o-ring areas and remove the grit or fine debris. Then, completely dry the area around male and female connector and the o-ring before re-connecting.

Camera Head: All Insight | VISION camera heads (CVSL) are covered for one (1) year under the standard warranty against all defects in workmanship. These cameras are all sealed and water proof. Warranty coverage will apply for any and all internal failures to the camera head unless external damage is evident. This would include a broken window and any deformation to the stainless steel metal housing of the camera head.

Insight | VISION has provided a small and large protective skid that **MUST** be used at all times. These skids are designed to aid in the centering of the camera head and have the added benefit of helping to protect the camera head from extreme wear. Failure to use the provided skids will result in direct wear to the front metal work area of the camera, resulting in the eventual wearing down of the metal work. This wear will result in a possible breach that will allow water to ingress into the camera head. This type of wear will not be covered under warranty.

Hub Assembly: The hub assembly houses the encoder, the wiring terminals, and solders joints that are susceptible to water damage. Although it is very well covered and enclosed, the electronic components are not water proof. Wipe with damp cloth when cleaning.

CAUTION: DO NOT POWER WASH THE HUB ASSEMBLY AREA.

Push Rod: Insight | VISION push rod terminations are covered for one (1) year under warranty. This warranty policy covers workmanship on the termination connection **ONLY** and does not cover push rod breakage or kinks in other parts of the rod.

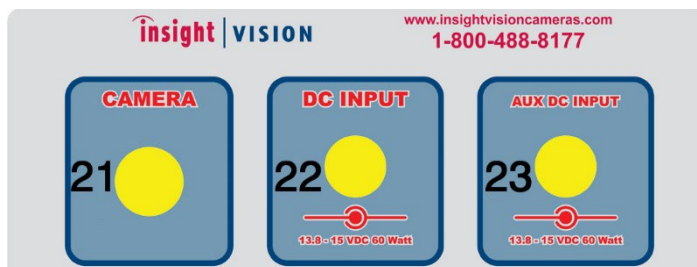
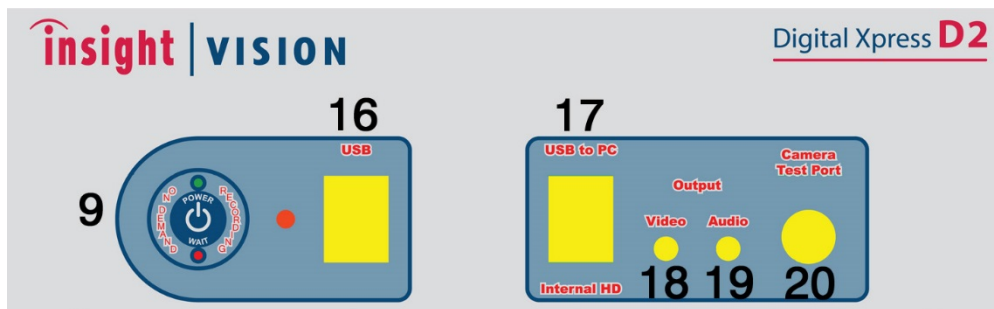
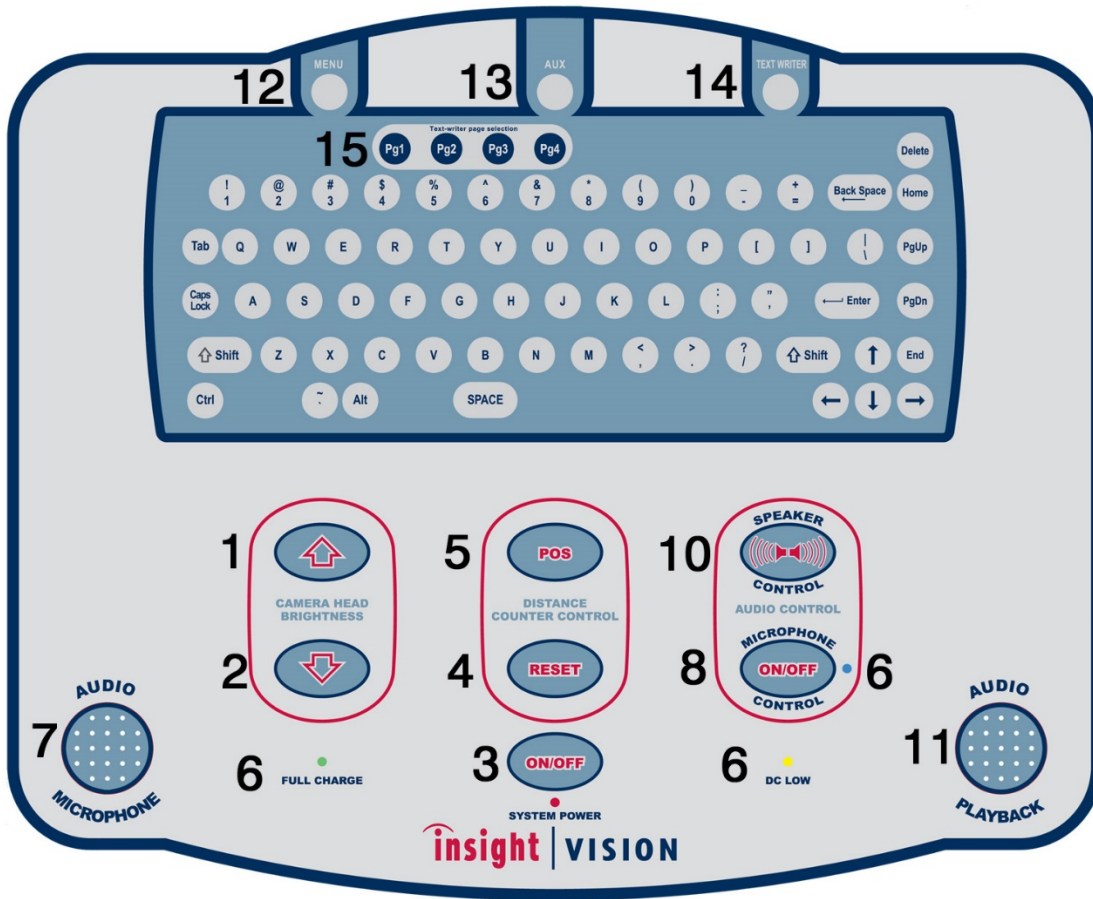



MAIN SYSTEM CONTROLS

1. Brightness Up - Increase brightness on the camera head.
"Recommend keeping the camera head at full brightness."
2. Brightness Down - Decrease brightness on the camera head.
"Adjust according to your applications."
Note: Do not turn light down all the way.
3. System Power **ON/OFF** button - **RED** LED indicates the system is ON.
"Wait for the LED light to stay solid RED before using."
4. On-Screen Distance Counter - The button will toggle 6 different display positions. *"Adjust according to your needs."*
5. On-Screen Distance Counter Reset Button - The button will reset distance counter to zero. *"Reset will toggle to default position."*
6. LED System Light Indicators:
 - A. Green **"Charging On"** LED
 1. ON Green - Full Charge
 2. BLINKING Green - Charging
 3. OFF Green - Not Charging
 - B. Yellow **"Power Low"** LED
 1. OFF Yellow - Normal
 2. 1/2 sec ON, 1/2 sec OFF - Power Low
 3. 1 sec ON, 1 sec OFF - System Fault
 - C. Blue **"Mic On"** LED
 1. ON Blue - Microphone ON
 2. OFF Blue - Microphone Off
7. Built-In Microphone and translucent remote window.
"Keep remote window clean for the best reception."
8. Microphone ON/OFF button - Blue **"MIC"** LED and on-screen **"MIC"** appear when ON.
9. On-Demand Recording ON/OFF Button. **Red** blinking LED indicates recorder is turning ON and will be ready for use shortly. **Green** LED indicates recorder is ON and is ready for use.



10. Speaker Volume ON/OFF button - Sound playback is available during video playback. Button will toggle volume from lowest to highest in 5 steps.
11. Built-In Speaker - For audio and video playback.
12. MENU Button - Menu button brings up the on-screen configuration menu. Please call Insight | VISION customer support for assistance. Also doubles as a “soft” key for on-screen display.
13. AUX Button - This button is used as a “soft” key for on-screen display
14. TEXT WRITER Button - This button is used as a “soft” key for on-screen display. Also doubles as a text-writer selection screen.
15. Text-Writer Page Selector - 4 pages
 - a. Pg 1 = No text. Distance counter only
 - b. Pg 2 = Contractor Form Page
 - c. Pg 3 = Client Form Page
 - d. Pg 4 = Free Form Page
16. USB to PC Port - Used to connect the Optional Internal Hard Drive to a P.C. to move files efficiently to an external computer.
17. Video Out Jack - Used for external video display device.
18. Audio Out Jack - Used for external audio display device.
19. Camera Test Port - Used for the camera head Diagnostic Port.
20. Main System Connection - Connection Port for the Video Interconnect Cable.
21. Main System Power Connection – Connection for the external 15V DC Power Supply cable. This connection will power your D2 Inspection Camera System and charges the internal rechargeable battery.
Note:
Advanced functionality recharges internal battery even when system is off.
22. Auxiliary System Power - Same as number 21 above but WITHOUT internal charging of battery.
23. Auxiliary System Power - Same as number 2 above but WITHOUT internal charging of battery.



REMOTE CONTROLS

Use GUIDE key to switch from "Camera View" to "Main Menu". Select "Camera View" from Main Menu to view live video.

1. One-Touch Recording Button - In camera view, press button to start video recording.
2. Display - Show additional information during video playback and recording.
3. Zoom - Zoom into video during playback. Use arrow buttons for additional functionality.
4. Select - Select file names when performing copy/paste/delete functions. Optional internal Hard Drive and external USB thumb drive.
5. Option - Use for additional file name functionality including file rename and deletion.
6. GOTO - Additional functionality during playback
7. GUIDE - Return to Main Menu System from Camera view.
8. OK Selection Button and Arrow Buttons - Used to Select highlighted items and navigate menu
9. Return - Return to previous menu item.
10. **Playback** = Video Functions:
Stop = Stop Recording or Playback.
Play = Play recorded videos.
Fast Rewind/Fast Forward Button = Fast-Forward and Rewind.
Previous/Next Button = Playback to go to previous or next recording
Slow = Slowing video during playback
Pause/Step = Pause video during playback





BASE FRAME

Horizontal Frame

The large base frame is a ruggedized steel reel designed to house 200' or 300' of the rigid (A) type rod or semi-rigid (B) type rod. This base frame comes with an integral digital footage counter. The design of this frame brings the push rod out from the front to allow for easy operation. When camera is not in use please store in basket. This frame has been designed with a pull out luggage style handle and wheels for easy transport. All anti-slide supports are made with a non-marring material safe for all floor surfaces. The top part of the base frame includes a mounting bracket for any of the D2 command module.

Stiff Rod

This push rod is .475" in diameter and has been specifically designed for longer pushing distances in 2"-12" pipe. Attempts should not be made to push this rod type through 2" 90 degree bends as rod breakage may occur. This rod type is only available in 200' and 300' lengths on the large horizontal base frame.

Debris Bag

This optional item comes in one sizes; one for each size of base frame reels. It is intended to minimize drippings while working indoors. It is easily removable for cleaning.



HEAVY DUTY HANDLE

COMMAND MODULE MOUNT

DO NOT POWER WASH

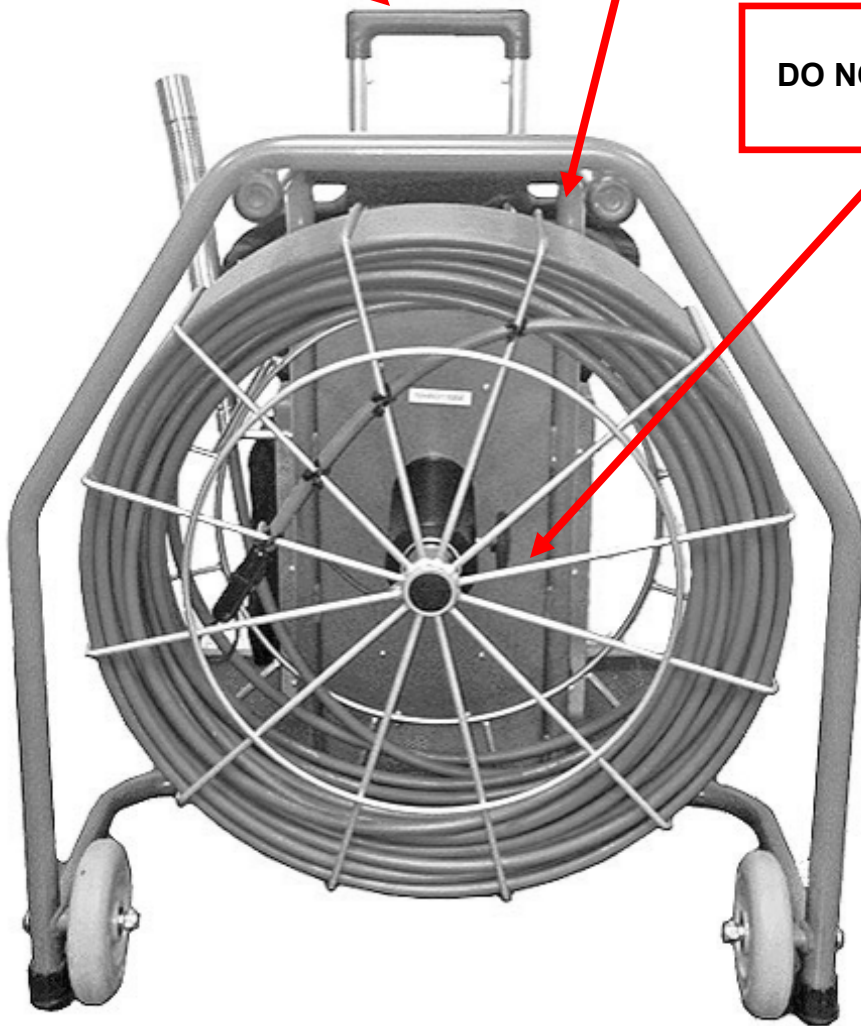



CAMERA

This camera has a self-leveling feature that will position the camera so that the top of the pipe will appear on the top of the display. This is a color camera with a LED light ring for illumination of the pipe being inspected. The camera module has an integrated auto iris feature, which will automatically adjust for varied light levels. The Sonde is not built into the camera. This camera is intended for operation in pipes 2-12" I.D. This camera will function with any of our D2 command module. Diameter of the camera head is 1.30". Best fit for pipe size of 2" to 12".

SELF-LEVELING CAMERA HEAD SPECIFICATIONS:

- ✓ *Repairable within 24 to 48 hours.*
- ✓ *Higher resolution and brightness*
- ✓ *Stainless Steel housing*
- ✓ *Water-Proof camera head*
- ✓ *Smoother Self-Leveling Camera head*





Sonde/Spring Assembly



The removable sonde is located inside the spring assembly. It continually transmits a signal at 512Hz, while the camera is turned on, and can be located with any locator capable of picking up a 512Hz signal.

Skid Set

The skids are intended to protect the camera from damage due to debris in the pipe being inspected.

The standard skids come in two sizes.

The 2" small skid is for use in 3-4" diameter pipes.

The 3" large skid is for use in 4-6" diameter pipes.



Skids Removal

The skid is one-piece device that affixes over the camera head. The skid is used to protect the integrity of the camera head and normal usage wear and tear. It is held down by three set screw. Use the Allen wrench provided by Insight | VISION in the accessory bag to loosen the skids to slide out the camera head.



F.A.Q

1. How do I record a video on my new D2 System?
 - a. Make sure the On-Demand Recorder is ON. From the Camera View mode press the ONE TOUCH RECORDING button (button 1 on the remote). Recording is indicated by a red dot on the upper left corner of the screen.
 - b. Stop your recording by simply pressing the STOP button on your remote.

2. How do I know if I am recording on my new D2 System?
 - a. While in Camera View mode, press the Display button (button 2 on the remote), if the system is recording the monitor will display the word "RECORDED" with a counter of time recorded.
 - b. If the system is NOT recording the monitor will display the time of day.

3. How do I play back my recording on my computer?
 - a. We have provided the portable D2 MEDIA PLAYER with your new D2 system for the most convenient option. The player can also be downloaded from Insight | VISION website.
<http://www.insightvisioncameras.com/support/usermanual/index.html>
 - b. Insert USB Memory Stick into your computer. From the USB Memory Stick, launch the D2 Media Player. Simply use the open file functions in the player to open and play recorded videos. Please contact your computer support person for additional information on playing videos on your specific computer.

4. Does my D2 system charge when the system is powered OFF?
 - a. Yes. The system will charge the internal battery if the system is plugged into the power outlet. However, the Green "Charging On" LED will not indicate status.

5. What connection will recharge and power my system?
 - a. The 15V Power Supply Cable needs to be connected to the DC receptacle labeled as "MAIN SYSTEM POWER". (#22 of Main System Controls)

6. Is it OK to leave my system plugged in all the time even when not in use for long periods of time?
 - a. Yes. It is perfectly OK to leave your system plugged in all the time.



Trouble Shooting Guide

1. Why is there fog inside my camera lens?
 - a. Water moisture indicates a failure of the camera head seal. The D2 Camera head was manufactured to the highest standards and procedures.
Please contact Insight | VISION for assistance in returning your system to its optimum performance. (TOLL FREE 800-488-8177)

2. What happens if I lose video during operation?
 - a. The loss of video during operation could indicate a number of different situations. Your D2 system includes exclusive live-personal support. Please contact Insight | VISION for assistance in returning your system to its optimum performance.

3. Why don't I see my distance counter on the screen?
 - a. Press the "POS" button (button 5) on the front of your D2 command module. The "POS" button toggles the position of the distance counter on the screen.
 - b. Please contact Insight | VISION for assistance if the distance counter fails to reappear after hitting the "POS" button.

4. What happens if I lose the LED lights on my camera head during an inspection?
 - a. Verify that the LED lights are fully bright by pressing the "UP" button, (button 1) on the front of your D2 command module, a number of times.



Trouble Shooting Guide (Continue)

- b. Remove camera from push rod and test camera for lights using camera test port of Command Module. (#19 of Main System Controls)
 - c. Disconnect push rod from basket at basket hub and connect camera to hub connection.
 - d. Do not increase light to full brightness contact Insight | VISION for additional support.
5. My D2 has been sitting on the shelf for a few weeks and it no longer seems to recharge properly.
6. The internal battery has completely discharged. You will need to disconnect/reconnect your power cable 3 or 4 times to condition the batteries for proper charging.
7. My D2 command module monitor is displaying in black and white.
- a. Your system is in PAL mode, this is caused when the video driver of the recorder system loses video signal with the camera head. The easiest fix is to cycle on and off the power button of the On Demand Recorder (button 9) on the front of the D2 command module.
 - b. Pal mode is activated when the camera head is removed and reconnected to the system while the On Demand Recorder is ON. (Hot Swapping the camera) Please assure that the camera head is attached to the system before the On Demand Recorder is turned ON.



TECHNICAL DATA SHEET

Camera

Self-Leveling :	Yes
Dia. x Length:	52.83mm Length X 32.99 Diameter
Skid Dia.;	2" & 3"
Weight;	5.9 Ounces
LED Illumination;	Hi-intensity LED's provide illumination
Imager Sensitivity:	1 Lux
Rod Compatibility:	Support for 2 wire 22 gauge conductors 1000ft. Long
Construction:	Stainless Steel Body
Submersion:	52 PSI @ 150 feet

Controller/Recorder

Physical:	12"L x 9"W x 11"H
Display:	720-480
Recording Capacity:	8 Gig
Keyboard:	Full QWERTY
Text Generator:	Yes
Counter:	Displays on screen FT/M
Digital Video Out:	No
Analog Video In/out::	Yes
Controls:	On Touch Recording
Power:	15V @ 4Amps

Push Rod/Frame

Cable Length:	200-300-400
Push Rod Diameter :	0.465-0.485
Overall Dimensions:	30"L x 16-1/2"W x 32-1/2"H
Weight:	62# (200 ft.)
Sonde:	512HZ Frequency



MANUFACTURER OF ADVANCED SEWER AND PIPE INSPECTION CAMERA EQUIPMENT

insight | VISION

800-488-8177



INSIGHT | VISION
600 N. DEKORA WOODS BLVD.
SAUKVILLE, WI 53080
PHONE: 800-488-8177 ~ FAX: 262-268-9952

WWW.INSIGHTVISIONCAMERAS.COM

SALES MANAGER: **Bob Masse**
EMAIL: bob@insightvisioncameras.com